

GB Instruction for use

# POWERTEX



## Mechanical Rack Jack PRJ-S2

User Manual



## POWERTEX Mechanical Rack Jack PRJ-S2 Instruction for use (GB) (Original instructions)

Read and understand this instruction manual before using the product. Failure to read these instructions may result in personal injury and/or property damage. Retain this instruction manual during the whole lifespan of the product.

### Product description

The POWERTEX mechanical rack jack PRJ-S2 is made from high strength steel and is available in several capacities. The lifting mechanism is well protected inside a steel housing preventing it from damages and dirt. The jack is intended to lift loads using only hand force by operating the crank handle. Brake pawls will hold the load in position when the handle is released. PRJ-S2 jacks are designed to be loaded on the top support or on the lower toe support. The jacks are intended to be used to temporarily lift the load until it can be landed safely on a stable support.

**Standard applied:** EN 1494

**Proof load testing:** Each jack has been tested 1,25 x WLL at the factory prior delivery.

**Temperature range:** -20°C up to +50°C.

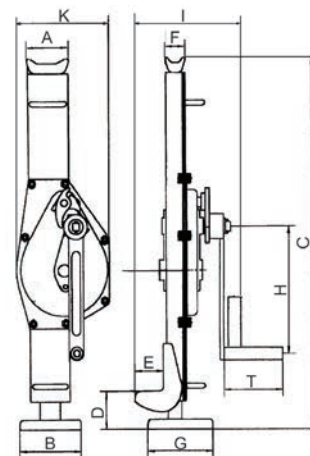

### Data

Part code	WLL (ton)	Crank force to lift full load N	Weight (kg)
16.35PRJS2015	1,5	186	13,5
16.35PRJS2030	3	250	21,2
16.35PRJS2050	5	245	28,5
16.35PRJS2100	10	392	46,8

### Dimensions

WLL (ton)	A mm	B x G mm	Lift height C mm	Heel height D mm	E mm	F mm	H mm	I mm	K mm	T mm
1,5	82	100x110	600-900	60-360	55	48	225	190	163	113
3	83	130x140	730-1080	70-420	60	45	250	200	197	127
5	106	140x170	730-1080	80-430	71	68	275	239	189	127
10	124	140x170	800-1210	85-495	86	76	300	293	250	248

Static test coefficient: WLL x 1,25

Generally according to EN 1494

### General instructions for safe work with jacks

Lifting operations using jacks must only be conducted by trained personnel.

Always follow national safety regulations.

Operate the equipment in accordance with the information in these operating instructions.

Check the equipment prior each usage and use only equipment being in perfect working order.

Important to use the jack on a substrate with sufficient load bearing capacity, else it could sink or topple and potentially drop the load.

Always be conscious of safety and aware of hazards when working with jacks as elevated heavy loads are involved.

Plan the lift carefully and ensure that the jack will be stable during the whole lifting operation.

Never exceed the working load limit WLL stated on the product identification plate.

Always lift smoothly and avoid shock loading as this could damage the jack.

Always lift with the load centered on the support areas.

During lifting and lowering movements always observe the movement of the load and lifting equipment.

When lifting the load with the toe support, the force transmission should be as close to the rack housing as possible.

If any problem with the equipment occur during use, the work must be immediately stopped, and the jack taken out of service for a thorough examination. Carry out necessary repairs before continuing to work!

Do not leave the load suspended without supervision.

Do not allow persons or body parts under a raised load until it has been properly supported by jack stands or other suitable supports.

Do not allow persons onboard the load being lifted.

Use only hand force to operate the handle, extensions are not allowed.

Transport the jack protected against impacts and shocks, falling over or toppling.

Keep a record of all jacks and other lifting equipment

A thorough inspection should be conducted and recorded by a competent person at least every 12-month ensuring that the jack is free from defects and that it operates perfectly.

### Usage exclusions

Not intended for permanent installations

Not intended to be used on vibrating loads

Not intended for use in explosive environments.

Not intended for use in chemical or corrosive environments.

Not intended for lifting hazardous loads.

**Description of parts:**

- 1) Base
- 2) Lever
- 3) Upper support stand
- 4) Lower support stand
- 5) Upper ratchet pawl
- 6) Lower ratchet pawl
- 7) Axle ring

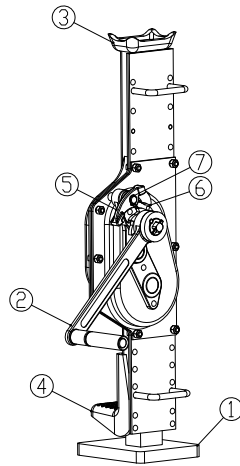
**Operation**

Place the jack under the load on a hard level surface. Place the jack so that the load can be firmly supported by the lower (4) or upper (3) support stand. Rotate the lever (2) clockwise by hand to lift the load and counterclockwise to lower the load. Never hold the gear rack while operating the jack as the housing will travel along the rack.

**Lifting with several jacks**

Lifting with 2 or more jacks simultaneously represent a high-risk operation.

There is a risk for uneven load distribution and overloading as one jack may take all the load whilst others become unloaded. This type of lifts must therefore be planned and supervised by a competent person with experience in this type of lifting.

**Maintenance and inspections****Daily inspection and storage**

Before each use, a visual inspection shall be made for any abnormal conditions, such as cracked welds, damage, bent, worn, loose or missing parts or illegible identification plate. Also check that the jack movement is operating smoothly. If any defect is detected or malfunction occur, the jack should be removed from service immediately and thoroughly inspected by a competent person. The jack should be thoroughly inspected immediately if it is suspected to have been subjected to abnormal loading or shock loading. Always store your jack in the fully lowered position.

**Thorough inspection**

At least every 12 months or shorter period if required by the working conditions a thorough inspection should be made by a competent person where the equipment is inspected for any damages such as missing parts, information plate being illegible, deformations, cracks and wear that may affect safety. Repairs needed shall be performed by an authorized customer service representative. Lubrication is needed to secure smooth function and to extend lifetime. Lubricate the gear rack regularly with heavy-duty water-resistant bearing grease and a light oil for the moveable crank house parts. The results of the thorough inspections should be recorded.

**End of use/Disposal**

Rack jacks shall always be sorted/scrapped as general steel scrap.  
Your POWERTEX distributor will assist you with the disposal, if required.

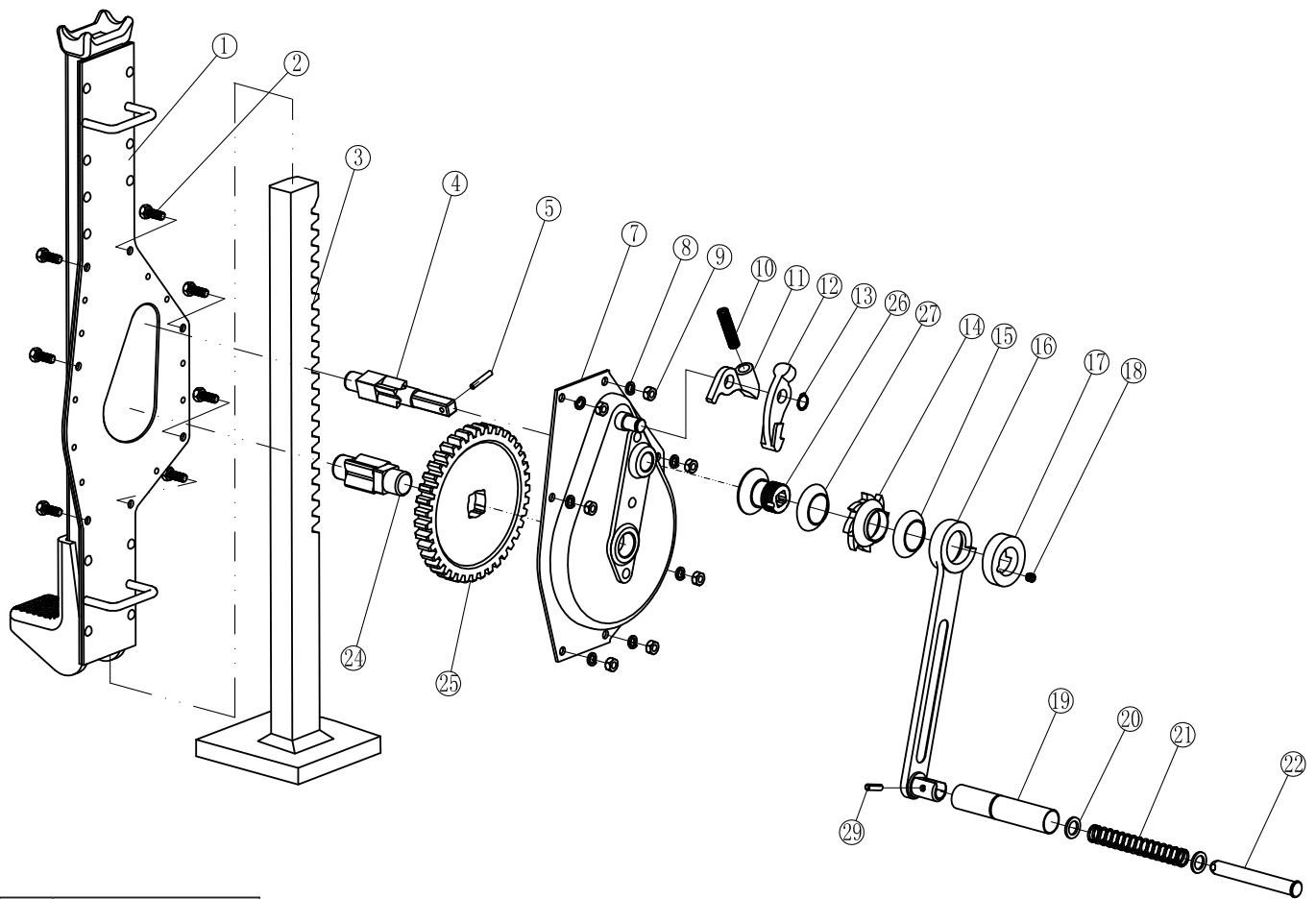

Pos	Description
1	Jack block
2	Screw
3	Rack
4	Axle
5	Elastic pin
7	Left bracket
8	Washer
9	Nut
10	Pawl spring
11	Lower ratchet pawl
12	Upper ratchet pawl
13	Axle ring
14	Ratchet wheel
15	Ratchet washer
16	Lever
17	Lock nut
18	Screw
19	Handle sleeve
20	Washer
21	Spring
22	Spring mandril
24	Axle
25	Gear
26	Axle seat
27	Washer
29	Elastic pin

**POWERTEX Rack Jack PRJ-S2 – Spare parts 3 t**

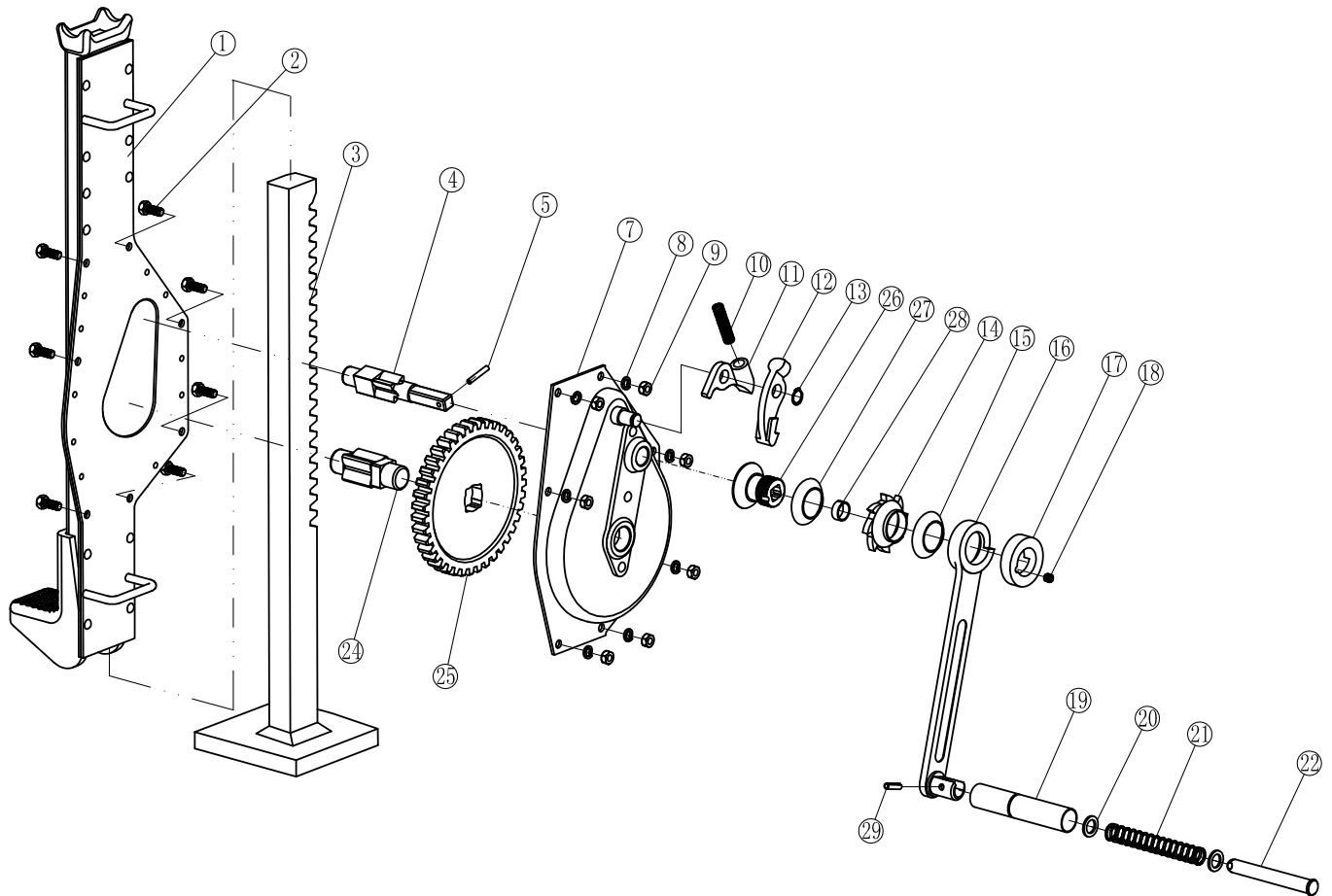

Pos	Description
1	Jack block
2	Screw
3	Rack
4	Axle
5	Elastic pin
7	Left bracket
8	Washer
9	Nut
10	Pawl spring
11	Lower ratchet pawl
12	Upper ratchet pawl
13	Axle ring
14	Ratchet wheel
15	Ratchet washer
16	Lever
17	Lock nut
18	Screw
19	Handle sleeve
20	Washer
21	Spring
22	Spring mandril
24	Axle
25	Gear
26	Axle seat
27	Washer
28	Sleeve
29	Elastic pin

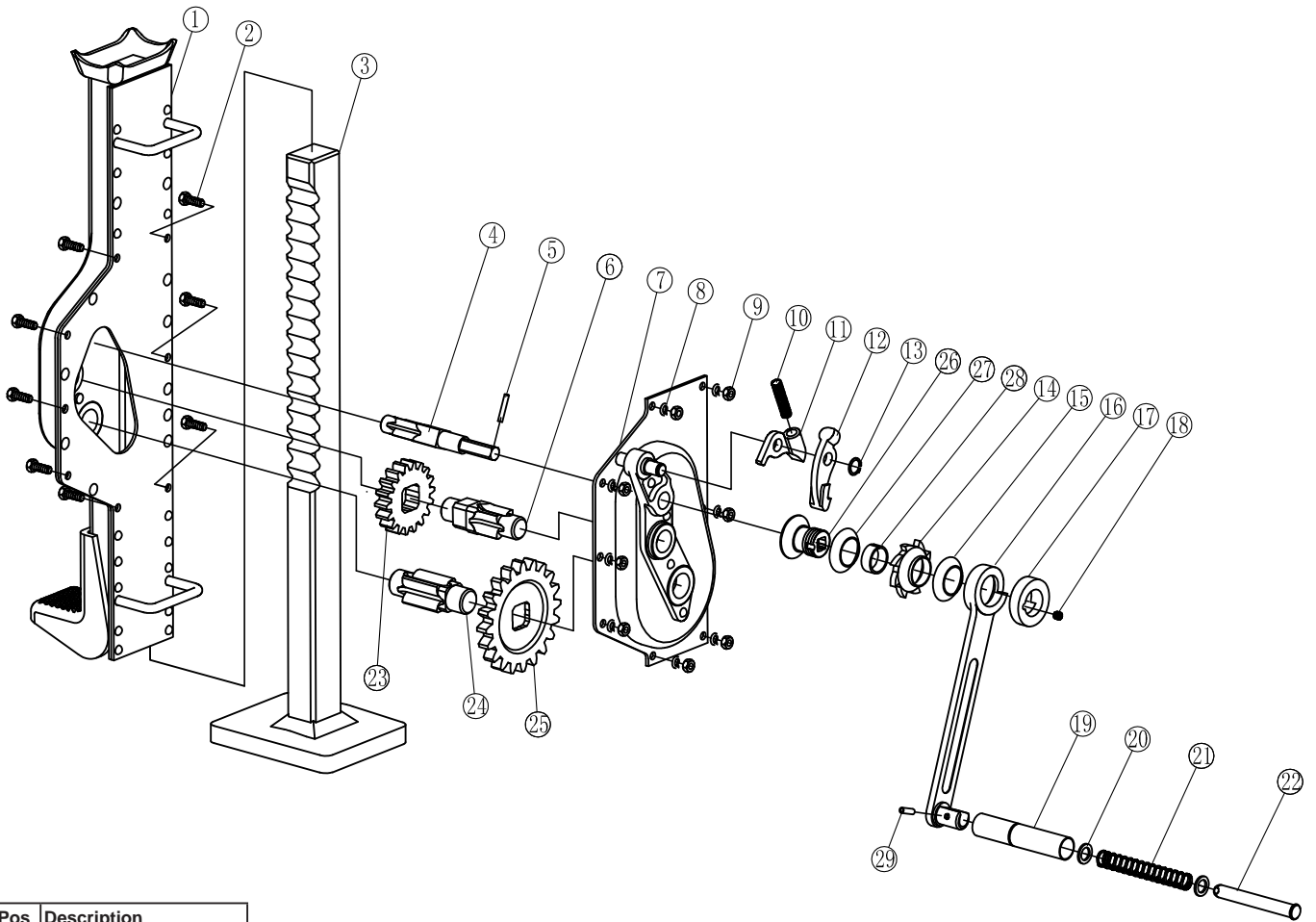

Pos	Description
1	Jack block
2	Screw
3	Rack
4	Axle
5	Elastic pin
6	Axle
7	Left bracket
8	Washer
9	Nut
10	Pawl spring
11	Lower ratchet pawl
12	Upper ratchet pawl
13	Axle ring
14	Ratchet wheel
15	Ratchet washer
16	Lever
17	Lock nut
18	Screw
19	Handle sleeve
20	Washer
21	Spring
22	Spring mandril
23	Gear
24	Axle
25	Gear
26	Axle seat
27	Washer
28	Sleeve
29	Elastic pin

## CertMax+

The CertMax+ system is a unique leading edge certification management system which is ideal for managing a single asset or large equipment portfolio across multiple sites. Designed by the Lifting Solutions Group, to deliver optimum asset integrity, quality assurance and traceability, the system also improves safety and risk management levels.

# CertMax

## Marking

The POWERTEX Mechanical Rack Jack is equipped with a RFID (Radio-Frequency IDentification) tag, which is a small electronic device, that consist of a small chip and an antenna. It provides a unique identifier for the block.

The POWERTEX Mechanical Rack Jacks are **CE** marked

Standard: EN 1494.



## User Manuals

You can always find the valid and updated User Manuals on the web. The manual is updated continuously and valid only in the latest version.

**NB!** The English version is the Original instruction.

The manual is available as a download under the following link:  
[www.powertex-products.com/manuals](http://www.powertex-products.com/manuals)



### Product compliance and conformity

SCM Citra OY  
Juvan Teollisuuskatui 25 C  
02920 Espoo  
Finland  
[www.powertex-products.com](http://www.powertex-products.com)



# POWERTEX

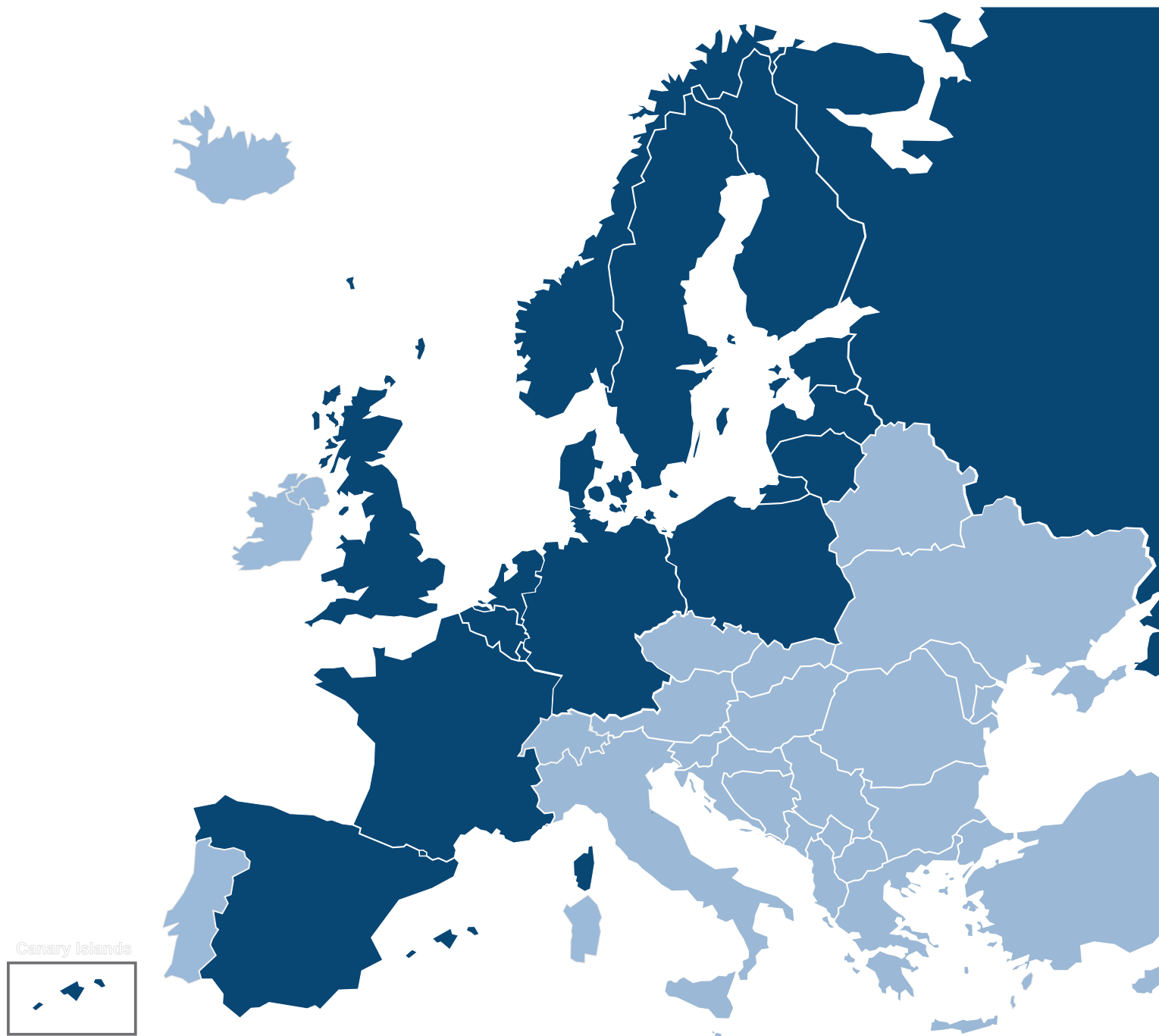

---

[www.powertex-products.com](http://www.powertex-products.com)