

Vertical Lifting Clamp IPU10J

Product information



The IPU10J vertical lifting clamp with larger jaw opening is used for lifting, turning, moving or vertical transfer of sheet, plates, or fabrications from horizontal to vertical and down to horizontal (180°) as needed. The hinged hoisting eye (a.k.a. universal eye) allows for the clamp to place and lift the load from any direction, or with a multiple leg sling without side-loading the clamp. Available in a variety of models:

- IPU10 - Standard clamp for materials with a surface hardness to 363HV10 (345 HB).
- IPU10J - Larger jaw opening.
- IPU10S - For use with Stainless Steel material.
- IPU10H - For use with materials with a surface hardness to 472HV10 (450 HB).

Features:

- Available in capacities of 0.5 thru 30 metric tons
- Higher Working Load Limits are available upon request.
- Wide variety of jaw openings available: 0 to 155 mm.
- Welded alloy steel body for strength and smaller size. Forged alloy components, where required.
- Individually Proof Tested to 2 times the Working Load Limit with certification.
- User manual and test certificate included with each clamp.
- Full 180° turning range for material transfer, turning or moving.
- Lock open, lock closed ability with latch for pretension on material and then release of material.
- For use with materials with surface hardness to 279HV10, only 5% min WLL is needed.
- Maintenance and repair kits are available.
- All sizes are RFID EQUIPPED.

[... Read more](#)

Material: Alloy Steel

Marking: According to standard, CE-marked, Logo, WLL, jaw capacity, serial number, proof load test date

Temperature range: -40°C up to +100°C

Standard: EN 13155

Vertical Lifting Clamp IPU10J

Blueprint

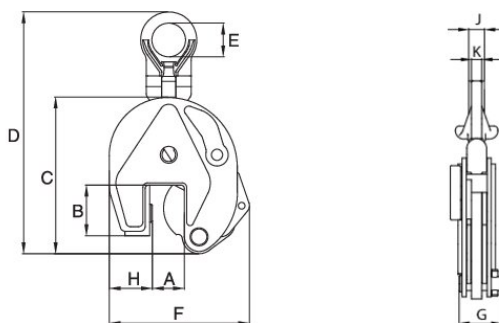

Technical data

Part code	Code	WLL ton	Jaw width mm	B mm	C mm	D mm	E mm	F mm	G mm	H mm	K mm	J mm	Weight kg
502100450801650	4.5-IPU10J	4.5	40-80	126	302	515	80	336	84	95	20	44	18.9
502100601001650	6-IPU10J	6	50-100	115	270	432	75	281	82	72	20	-	26.5