

Electric Chain Hoist KITO EQM with Motorized Trolley

Product information



Ultimate lightweight and compact size, meticulous and dedicated design, with integrated body protecting the high-performance and highly functional unit.

- The combination of idea and technology materialize in a lightweight size.
 - Meticulous inverter-dedicated design
- A dual-safety mechanism prevents accidents from excessive loads.
 - Equipped with a friction clutch and electronic overload limiter
- Smooth and ergonomic operation
- Shuts off motor current during excessive lifting/lowering to prevent accidents.
- Meticulous long-life design
- Suitable for severe environments and working conditions
 - Simple design with Grade M6 High-end duty rating with unique motor frame fins and fan cover
- World-class KITO original chain - Superstrong nickel-plated load chain
- Visual indication of maintenance timing
- Shuts off the motor circuit in case of emergency.
- Higher inspector work efficiency - Easier maintenance
- Environmentally friendly
- Use:
 - Lifting Up/Down, Traversing Left/Right

... [Read more](#)

Temperature range: -20°C up to 40°C

Electric Chain Hoist KITO EQM with Motorized Trolley

Blueprint

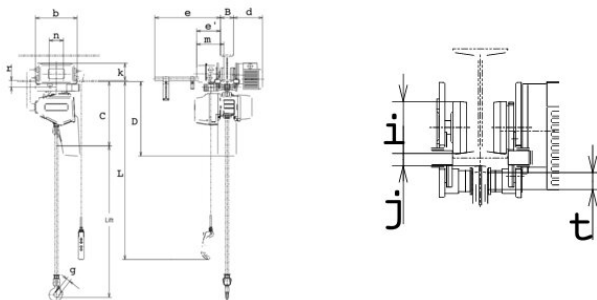

Technical data

Part code	Code	WLL ton	Lifting height m	Lifting speed m/min	Number of falls	Beam width	Motor kW	Traversing motor Output kW	Lifting speed m/min. High (light load) 0-30 % WLL	Lifting speed m/min. High 30-100 % WLL	C mm	D mm	b mm	d mm	e mm	e' mm	g mm	i mm	j mm	k mm	m mm	n mm	r mm	t mm	Weight kg
540100101500464	EQM010IS-IS	1	3	7.1/1.2	1	58-163	1.5	0.4	9.2	7	490	565	315	220	515	179	31	95	22	130	205	109	51	31	75